



Impact of PV inverters on PLC based Smart Metering Systems



Aleksander Babś
Advant sp. z o.o.

20.05.2021

PLC as a first choice for AMI systems

- PLC (powerline communication) is currently the most used method to transmit data in national smart metering systems
- Over 2 million meters utilizing various PLC technologies, approx. 80% in PRIME 1.3.6 CENELEC band
- PLC is still the cheapest method of sending data (<10 USD for complete communication path including LV coupling, control and transmit logic)
- In general, PLC meters support automatic topology creation of devices, based on implemented algorithms and, as a result are cheap in deployment and maintenance. Cases demanding more effort (clean up) are rare. They are mostly caused by devices connected to LV network, generating disturbances in frequency band used by PLC of sufficient power
- **PV inverters as, power electronic devices can also be a source of disturbances affecting performance of PLC transmission technologies**

PV inverters and PLC – what do they have in common?

- PLC in band <500 kHz is formally a Narrowband PLC, NB-PLC
- CENELEC A - 3 kHz - 95 kHz is the most frequently used band in European AMI systems

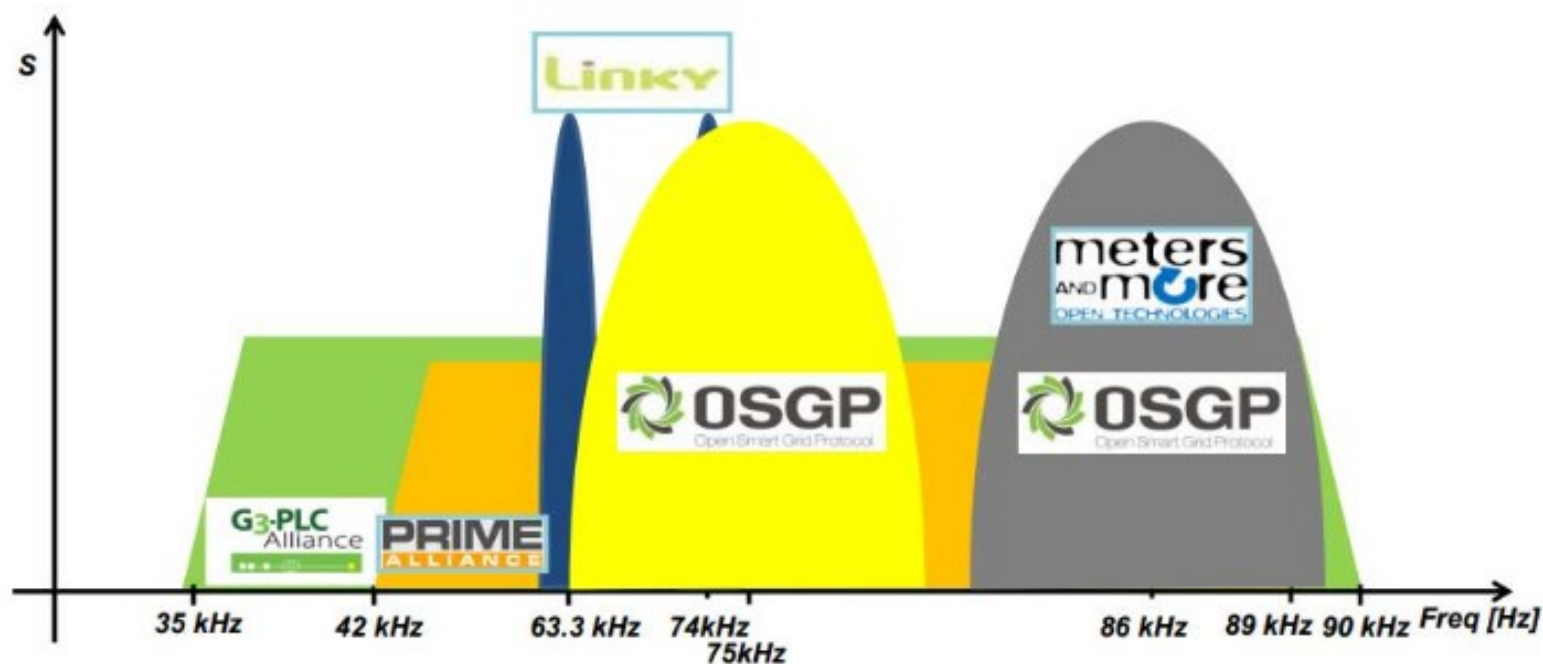

- It is a band which contains typical operating frequencies of switching circuits based on IGBT and MOSFET transistors used in transformer less PV inverters

PV inverters – typical hardware build

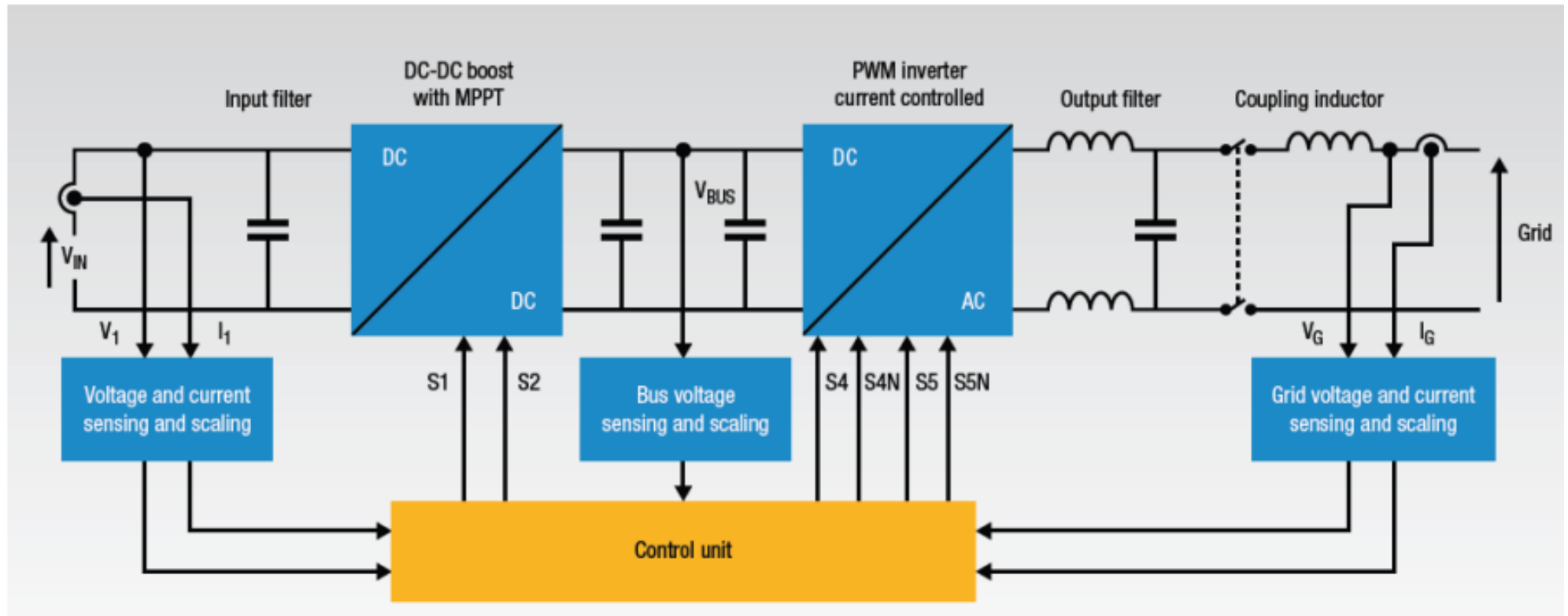

Inverters are non-trivial power electronic devices, which are used to transform direct current (DC), generated by solar panels, into alternating current (AC) meeting requirements that would allow the inverter to be connected directly to the grid (on-grid) or to power typical devices (off-grid).

Conversion of direct to alternating current is performed by PWM circuit, operating at specified frequency.

PV inverters – PWM operating frequencies

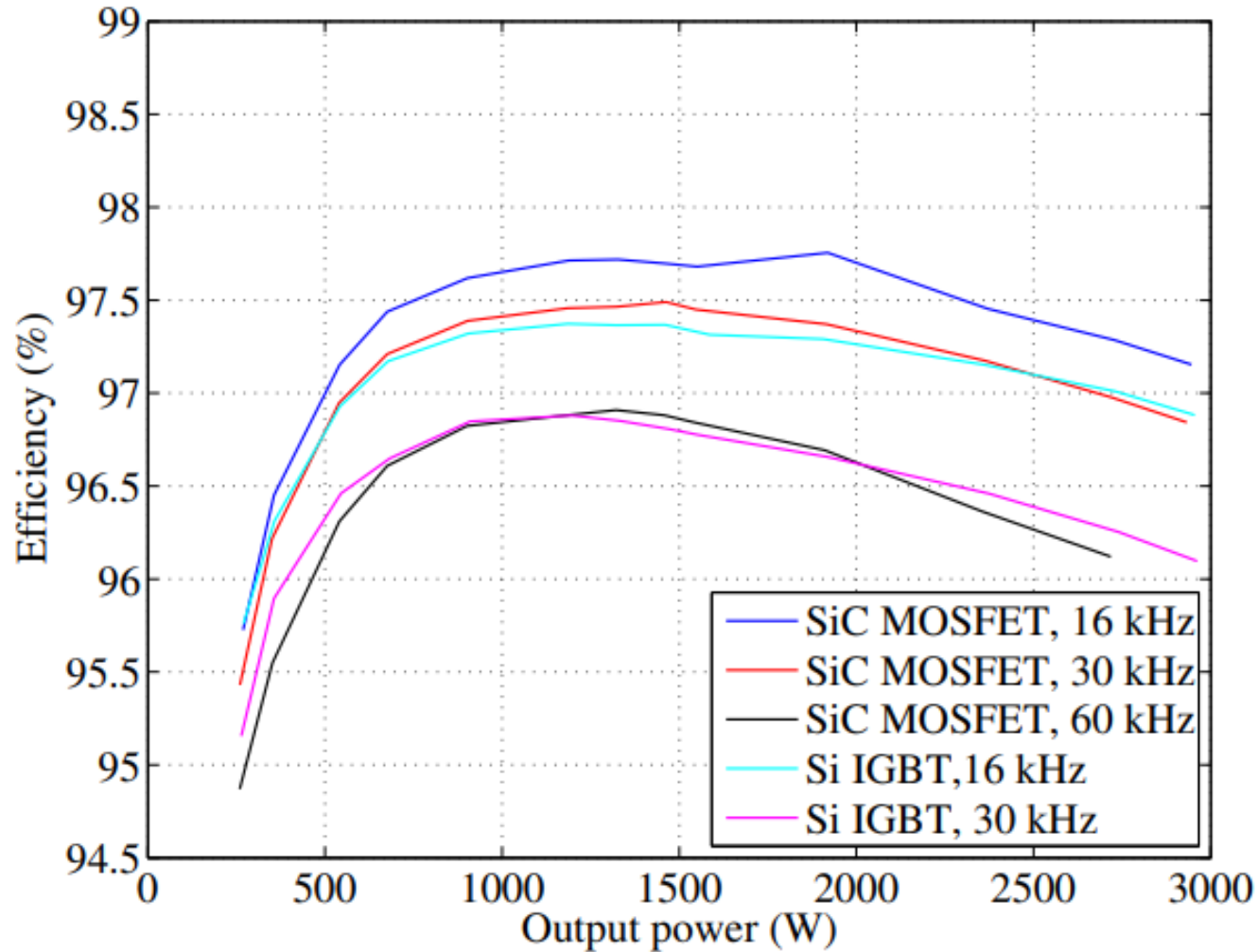

Frequency of 60 kHz is in frequency band utilized by PRIME PLC and G3-PLC

PWM operating frequencies and CENELEC A

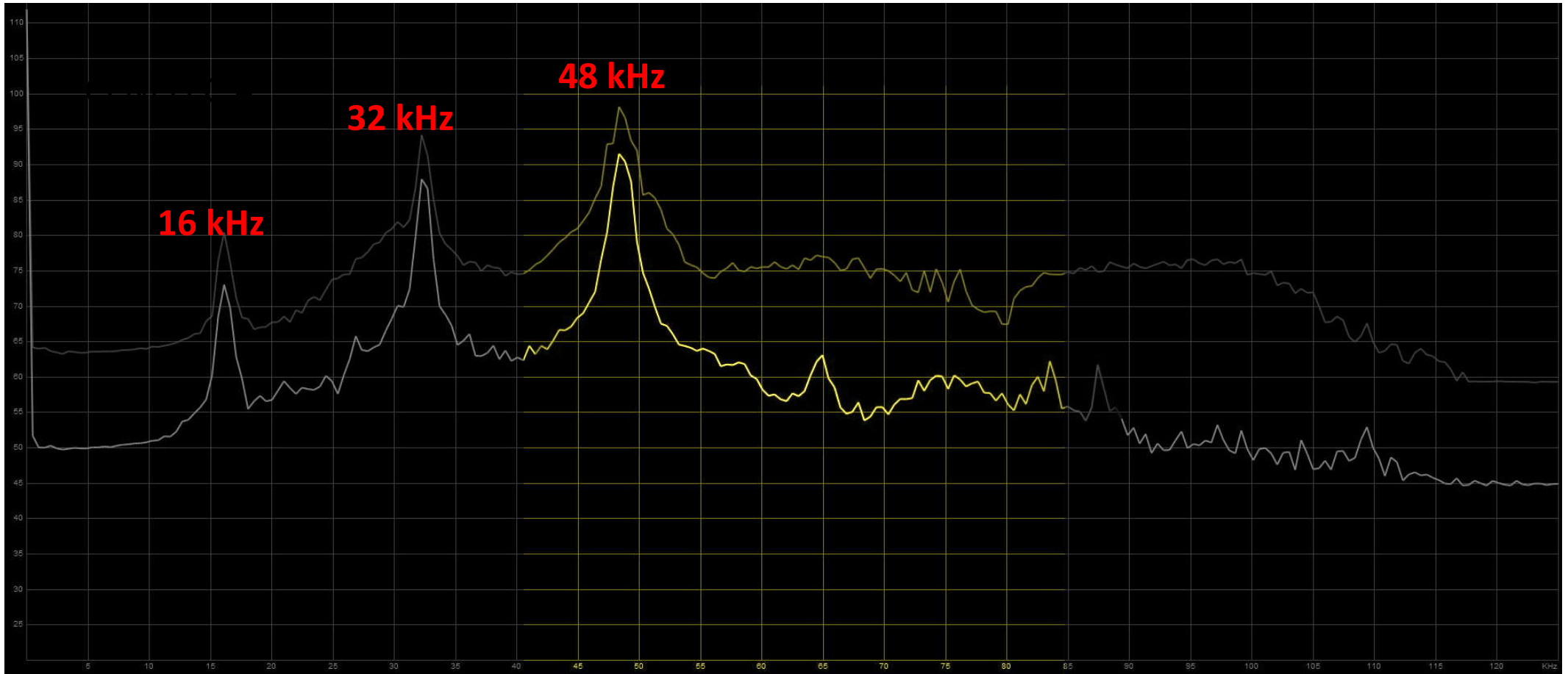

CENELEC A

Frequency spectrum of a PV inverter, which PWM circuit is operating at base frequency of 16 kHz, generating harmonics of 32 kHz and 48 kHz

Disturbance and standards

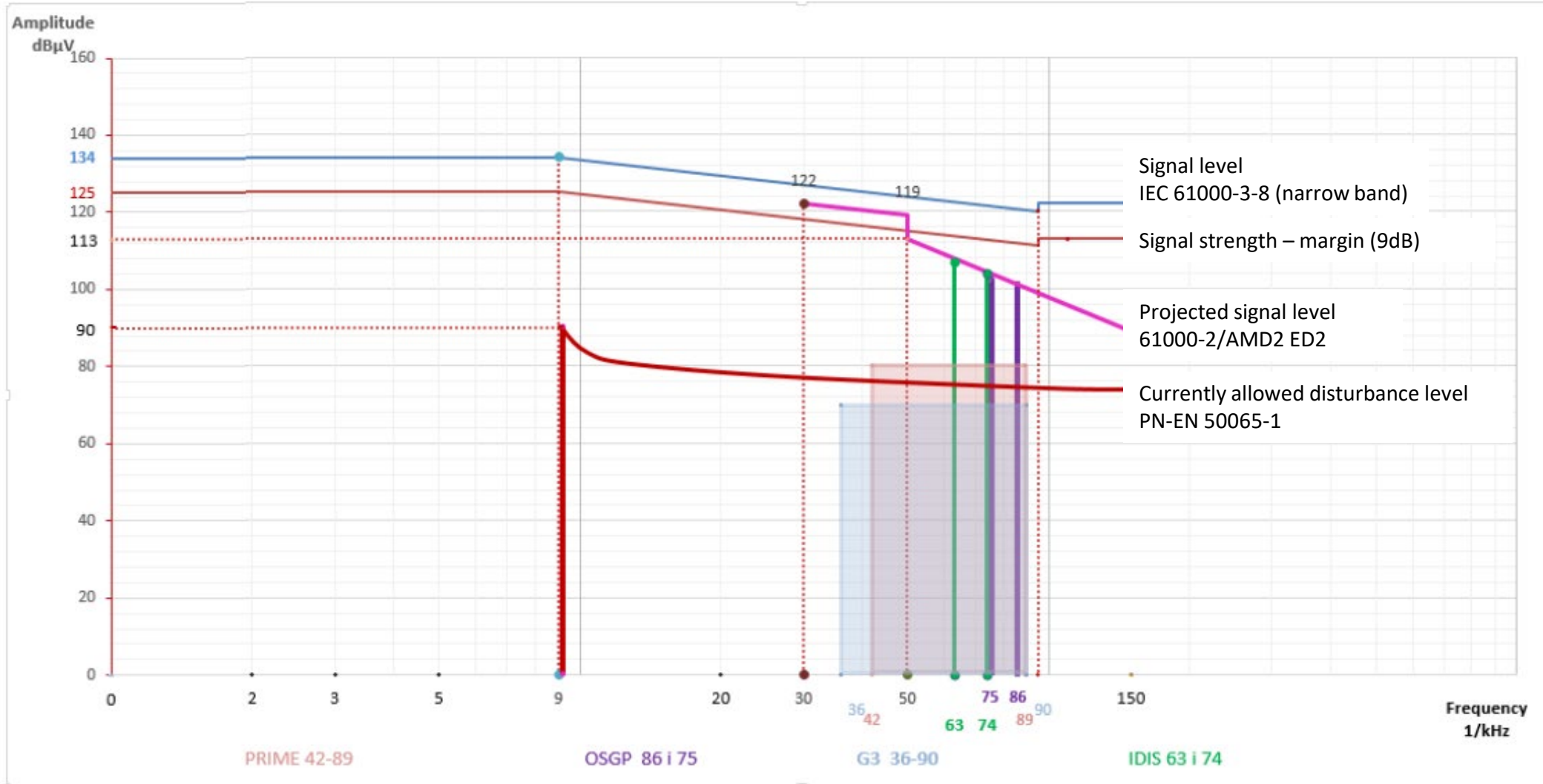

Source: "Zakłócenia przewodzone w publicznej sieci elektroenergetycznej niskiego napięcia oraz ich wpływ na komunikację PLC w paśmie CENELEC A", Politechnika Wroclawska, Tauron Dystrybucja Pomiary sp. z o.o., 2018

After superimposing EN 50065 on spectrum...

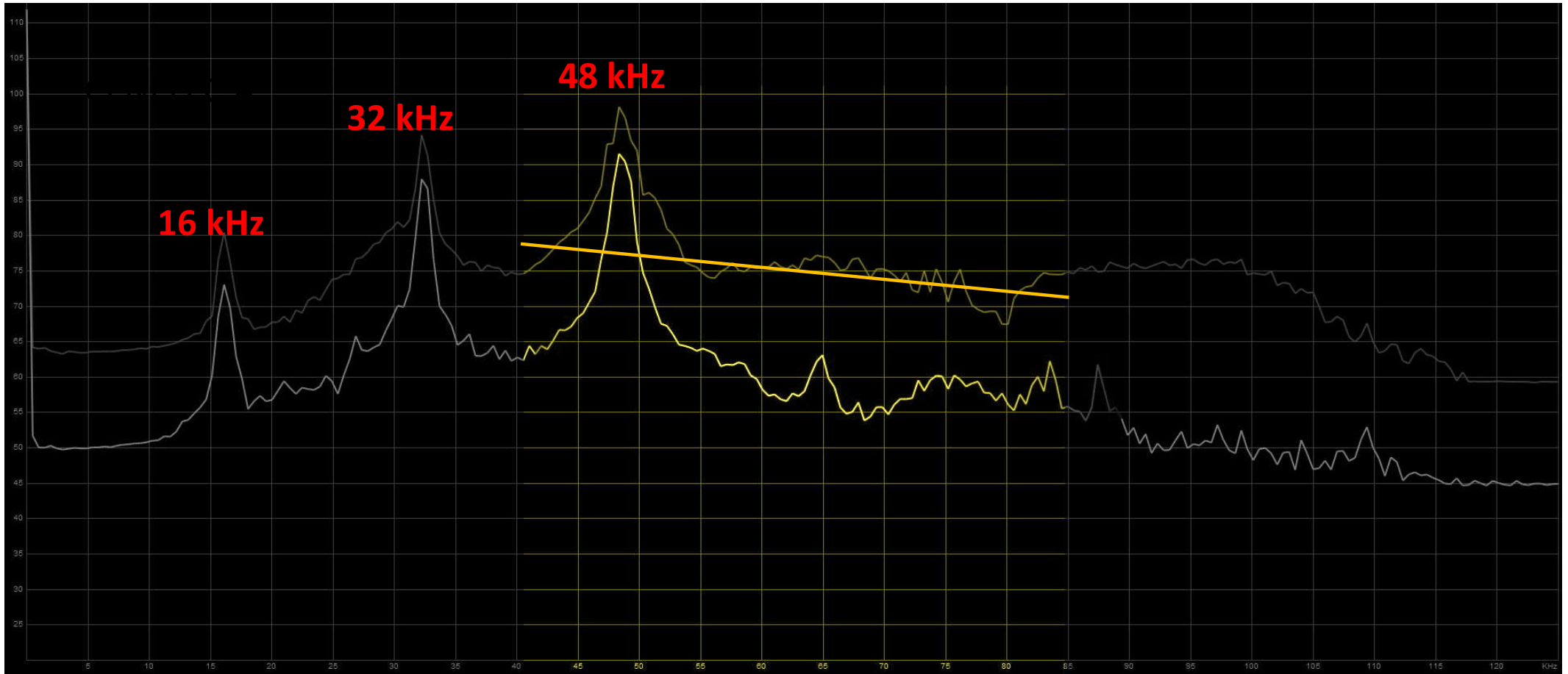

CENELEC A

Inverter under test generates disturbances above allowed range allowed by PN EN 50065-1 at 48 kHz

OSGP frame

Low probability of disturbances being generated by PV inverter on OSGP frequencies of 75 kHz and 86 kHz

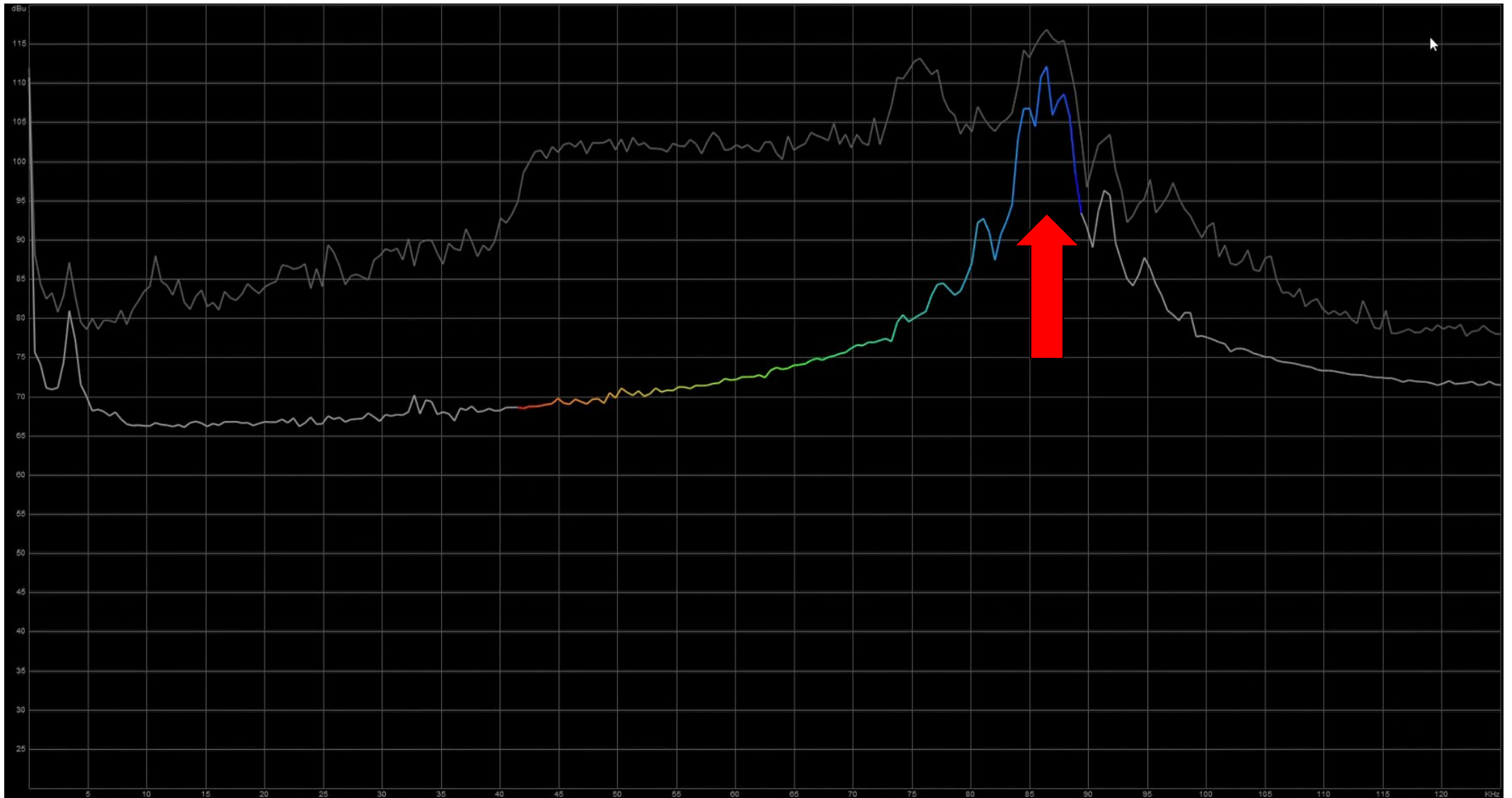

PRIME frame

Significant probability of disturbances being generated by PV inverter on PRIME operating frequencies - 42 kHz to 89 kHz (97 subcarriers spaced 488 Hz)

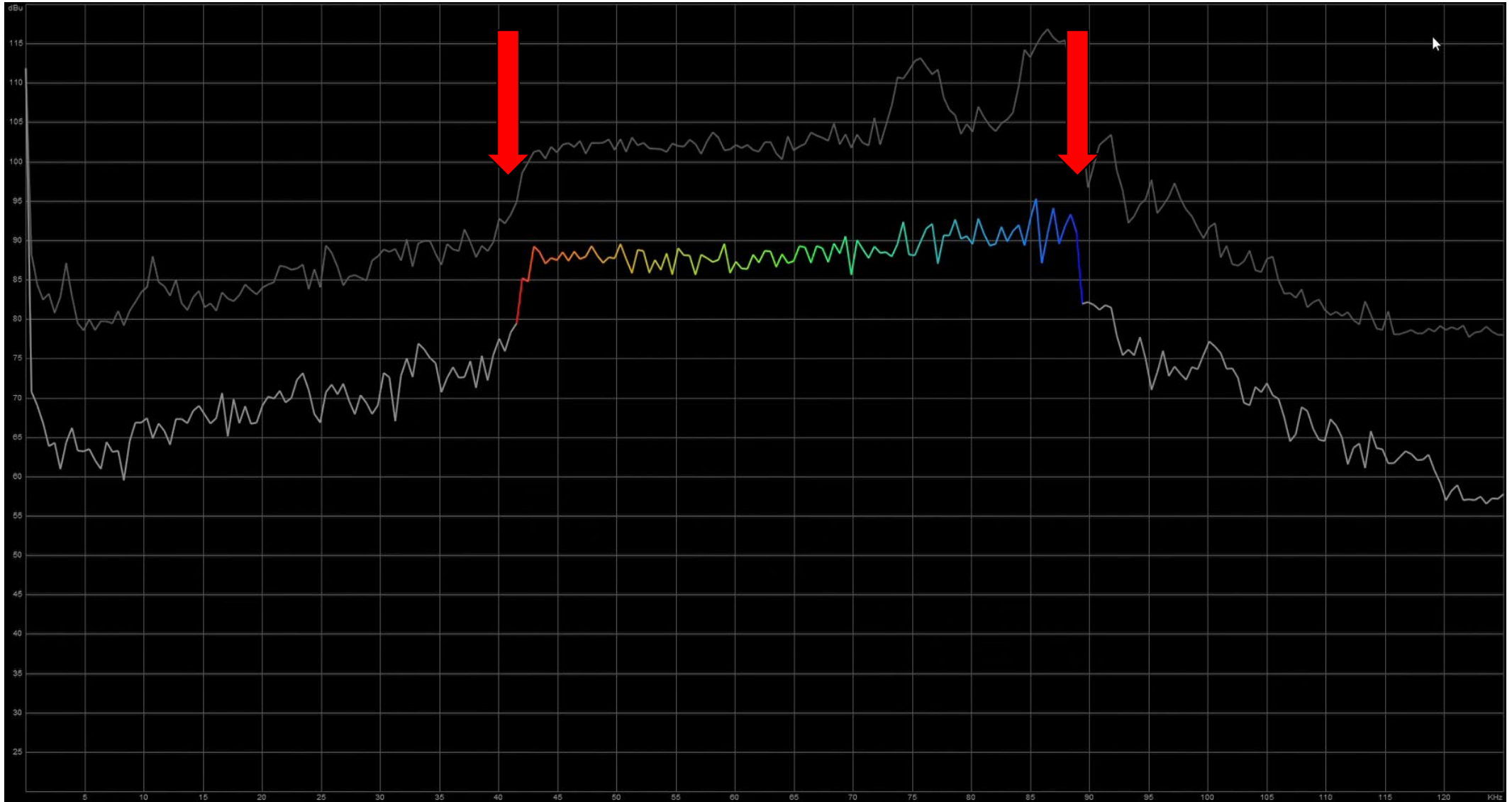

Disturbances

Inverter 1 Unknown source Inverter 2 Inverter 3
30 kHz and 60 kHz 50 kHz 65 kHz 95 kHz



Disturbances

Inverter 1
16 kHz + 32 kHz + 48 kHz + 64 kHz

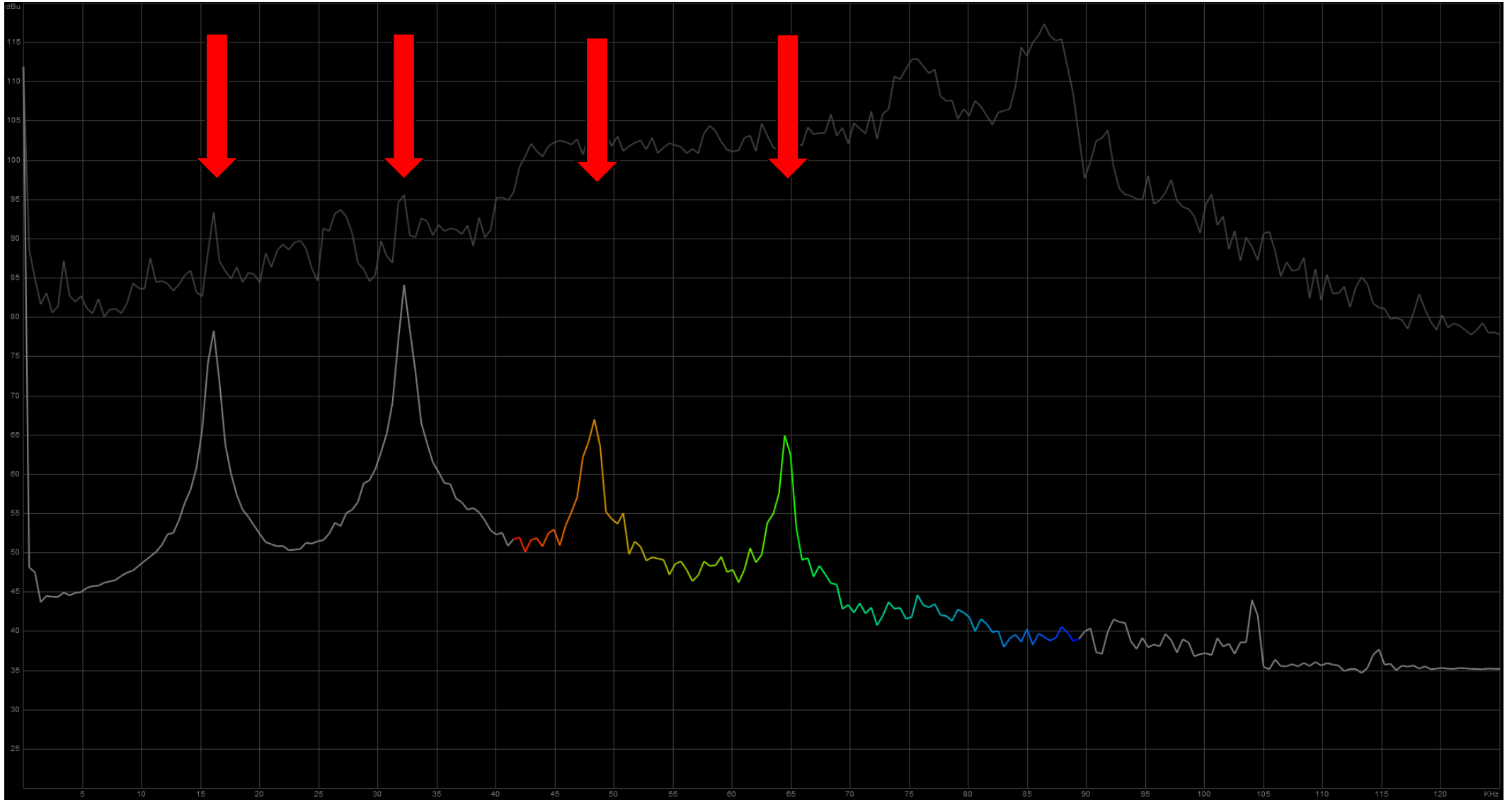

Communication quality tests – testbed design

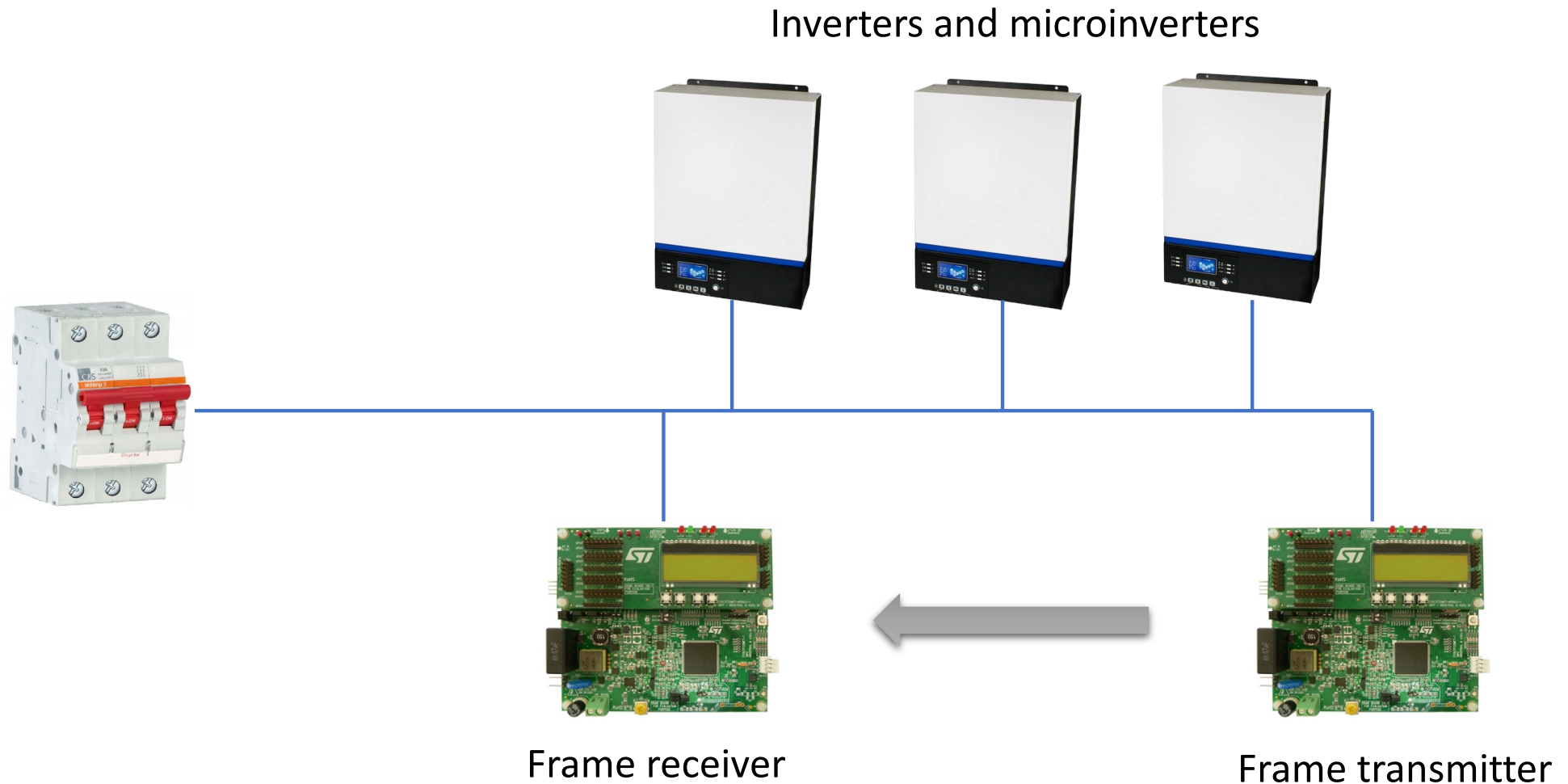

Communcation quality tests - PRIME

Despite disturbances induced by PV inverters, all frames were sent without errors (bit error rate = 0). Observed disturbances did not have an impact communication quality

BER

Open COM Port

SN1: COM8, TX checked, Open/Close buttons

SN2: COM10, TX unchecked, Open/Close buttons

SN TX: 0080E14889A5, SN RX: 0080E1485AC5

Set Parameter

Header (54 bits): 3FFFFFFFFFFFFF

Payload (max 377 bytes): aabbccddeeff

Len: 6

Lvl: 0(max) - 7(min): 0

TX Scheme: 4: BPSK-FEC

Time (100-5000ms): 100

Num TX (1-100000): 30

Start BER Test, Stop BER Test

Result Test

Num Tx: 30, Pkt Rcv: 30, FER: 2.000000E-001

Statistical attribute: PhyStatsCRCIncorrectCount: 0, PhyStatsCRCFailCount: 0

PHY Header Wrong pkt: 0, 0.000000E+000 %

100%

Log:

```
PIBAttr: 0x00a1 phyStatsCRCFailCount
Value[hex]: 0000
Status: 00 Success or Done
-- 20 maj 01:19:50 --
BER TESTER: START
-- 20 maj 01:20:03 --
BER TESTER: STOP
-- 20 maj 01:20:03 --
BER TESTER STOP
-- 20 maj 01:20:03 --
BER TESTER: COMPLETE
-- 20 maj 01:20:03 --
BER TESTER: STOP
```

Summary:

Bit Sent:	3060
Bit Rcv:	3060
Wrong RX bits:	0
BER:	0.000000E+000

AMI PLC vs PV – possible technical solutions

- Use of PLC technologies which allow to disable frequencies in risk of being disturbed (e.g. G3-PLC tone map)

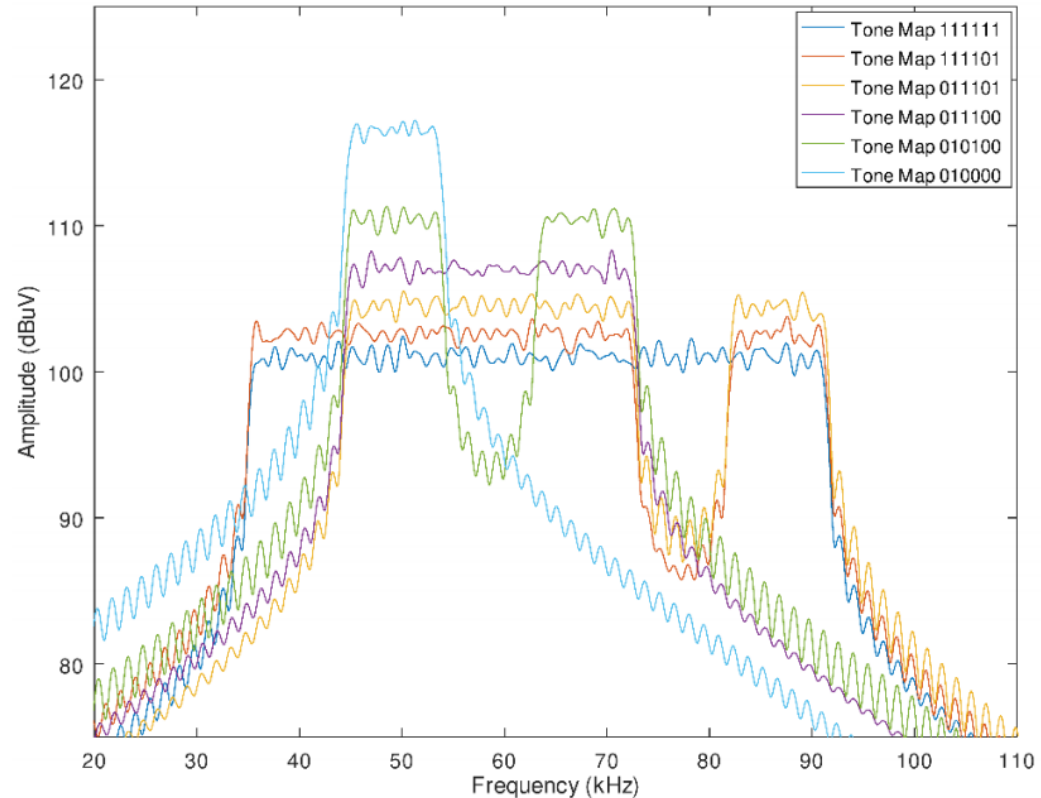

- Use of PLC technologies with mechanisms improving resilience to disturbances (e.g. ROBO mode in PRIME 1.4)
- Use of higher frequencies e.g. 350kHz – 500 kHz from FCC band, which is less disturbed than CENELEC A band

Conclusions

- None of 8 string inverters and 2 microinverters did not generate disturbances negatively affecting PRIME nor OSGP communication. 1 model however, was not compliant with PN EN 50065-1
- If, after starting a PV inverter, PLC communication quality deteriorates in a given segment of low voltage grid, it can be assumed that this is caused by the inverter
- PLC technologies using OFDM – a number of subcarriers in within a specified frequency range, are more susceptible to disturbances generated by inverters than technologies using two frequencies (primary and secondary) as in OSGP for example
- Current active power output (e.g. 10% and 90% of rated power) does not affect the level of generated disturbances
- There are laboratory methods which allow to precisely study the influence of a particular PV inverter on a given PLC technology



Thank you

Aleksander.Babs@advant.pl